

Ref: 40.031

Features:

- Protections: Overload / Over voltage / Short circuit / Over Temperature
- Cooling by free air convection
- Universal AC input range
- Protection degree: IP67
- Protection class II
- Constant voltage design



Electrical characteristics	Power (W)	150W
	Voltage (V)	12V
	Output current range (A)	0 ~ 12.5A
Input specifications	Input voltage range	180-277Vac; 254-390VDC
	Input frequency range	47Hz - 63Hz
	Efficiency	92%
	Input AC current	1.7A / 20VAC
	Inrush current (typ.)	50A / 230VAC; TWIDTH (50% peak) = 1200µs
	Leakage current max.	0.25mA / 240VAC
Output specifications	Output rated current	12.5A
	Output line regulation	±2%
	Output load regulation	±2%
	Output tolerance	±5%
	Ripple and noise	300mV
	Setup, rise time	500ms, 50ms / 230VAC at full load
	Hold up time	18ms / 230VAC at full load
Protections	Over Current	Range: 110% - 180% rated current / Type: hiccup mode, auto-recovery.
	Short circuit	Type: hiccup mode, auto-recovery.
	Over voltage	18 ~ 30V / Type: hiccup mode, auto-recovery.
Working environment	Working temperature	-20°C - 70°C (Refer to Derating Curve)
	Working humidity	20 - 95% RH non-condensing
	Storage temperature and humidity	-40°C - 80°C, 10 - 95% RH non-condensing
	Temperature coefficient	± 0.03% / °C (0°C - 50°C)
	Vibration	10 - 500Hz, 2G, 10min / cycle, period for 60min. each along X, Y, Z axes
Other	Dimension	230x70x45mm
	Weight	1.15Kg
	Guarantee	5 years



Assembly and safety information

Applied standards:

- EN 61347-1
- EN 61347-2-13
- EN 55024
- EN 61000-3-2
- EN 61000-3-3
- EN 61547
- EN 61000-4-2
- EN 61000-4-3
- EN 61000-4-4
- EN 61000-4-5
- EN 61000-4-6
- EN 61000-4-8
- EN 61000-4-11
- EN 55015

Measurements:

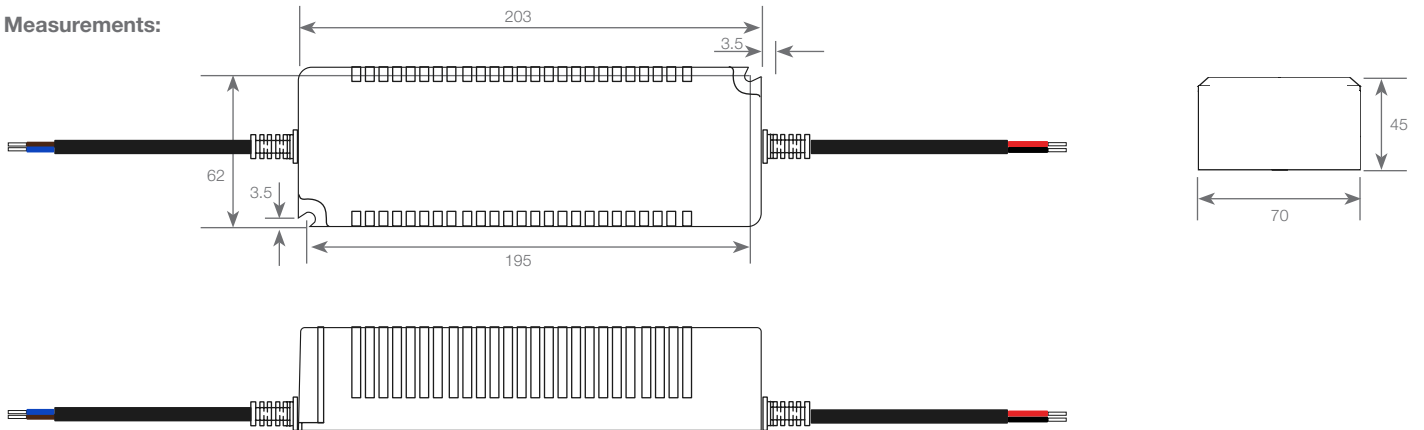
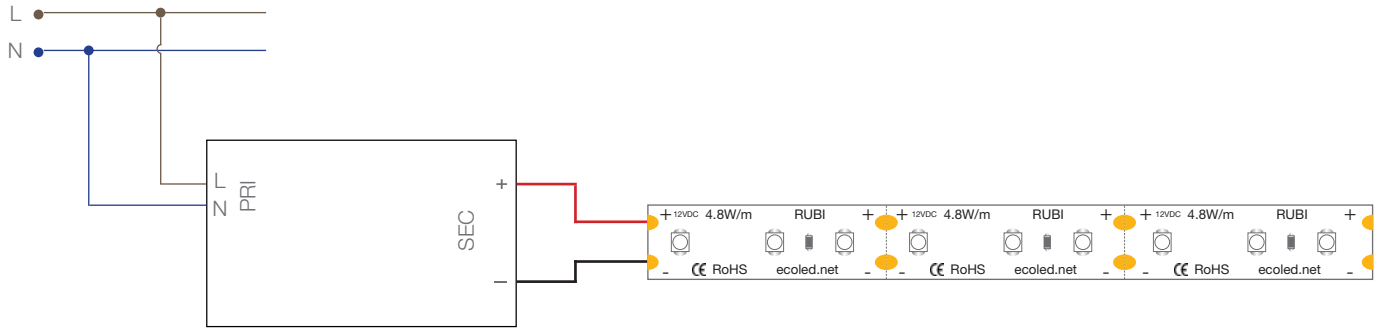
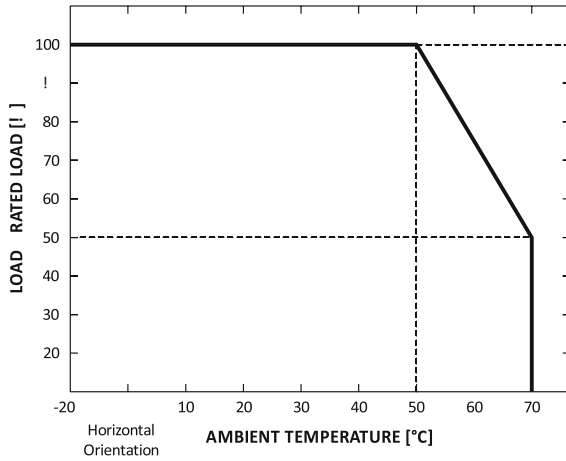

Diagram:



Graphics:

Derating curve



Static characteristic

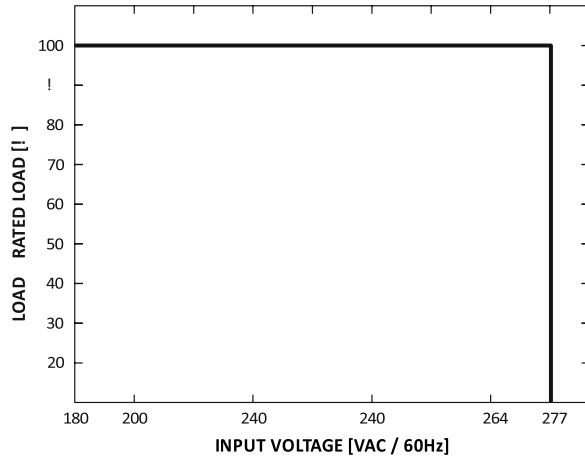

Lifetime UV. Ambient temperature curve

